

# BI-650 Industrial Conductivity Controller

## USER MANUAL

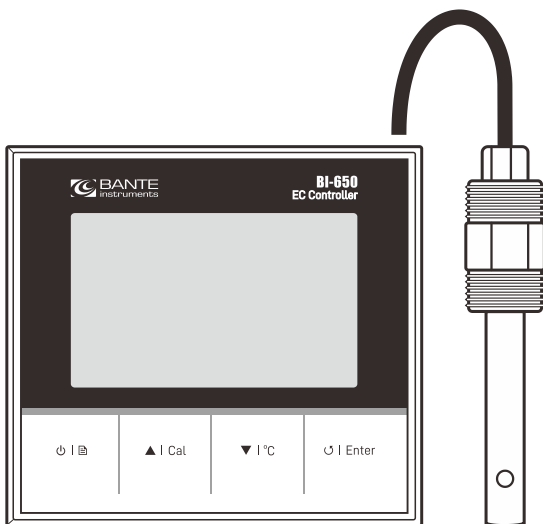

## Introduction

Thank you for selecting the BI-650 industrial conductivity controller. This user manual provides a step-by-step guide to help you operate the meter, please carefully read the following instructions before use.

### Environmental Conditions

Before the installation, ensure that current environmental conditions meet the following requirements.

- Relative humidity is less than 80%
- Ambient temperature between 5°C (41°F) and 50°C (122°F)
- No potential electromagnetic interference
- No corrosive gas exists

### Packing List

The following list describes all components of the meter. If any items are missing or damaged, contact the supplier immediately.

---

BI-650 conductivity controller

---

IE-50MT industrial conductivity electrode

---

Conductivity standard solution 1413 µS/cm

---

## Installation

### Safety Warning

- BI-650 meter shall be installed and operated only in the manner specified in this user manual.
- Only skilled, trained or authorized person should carry out installation, setup and operation of meter.



- The rear panel of meter has two screw terminals for connecting the 24V DC power supply. Make sure to cut off the main power before installation and maintenance.
- Once the power supply cable is connected to the meter, DO NOT touch any screw terminals.

### Installing the Meter

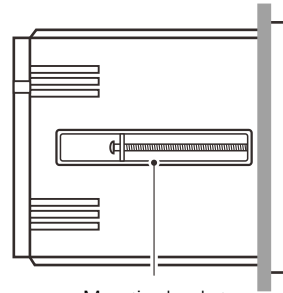
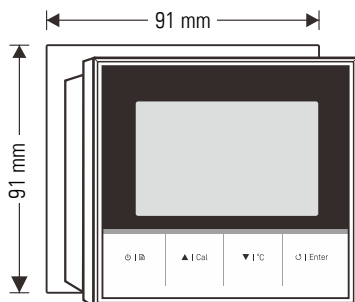

Mounting bracket

- 1.1 Cut out a square hole approximately 91 × 91 mm (3.58 × 3.58 in.) in the mounting panel.
- 1.2 Remove the mounting bracket, place the meter into the square hole.
- 1.3 Replace the mounting bracket and push the meter forward until it is fully seated on the mounting plate.

### Installing the Electrode

- 2.1 Wrap Teflon tape to the electrode body threads.
- 2.2 Insert the electrode into the mounting position and slowly turn clockwise until secure. Hand tighten the electrode to prevent liquid leakage.

- i** Selectable mounting positions

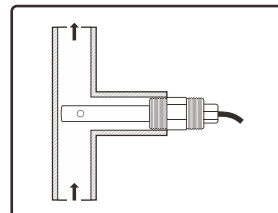
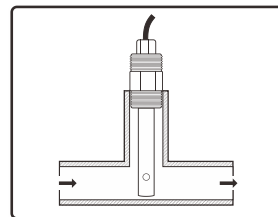
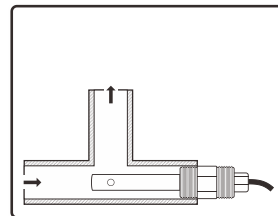

The arrow represents the direction of the liquid flow.

## Connection

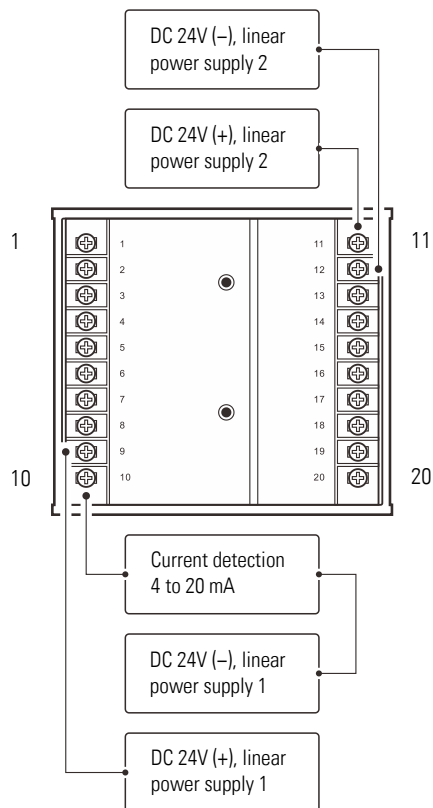

No.	Terminal	Description
1	---	No connection
2	EC (+)	Conductivity/TDS input (+)
3	EC (-)	Conductivity/TDS input (-)
4	---	No connection
5	TC (-)	Temperature input (-)
6	TC (+)	Temperature input (+)
7	485 (B)	RS485 signal output (B)
8	485 (A)	RS485 signal output (A)
9	DC 24 (+)	DC 24V (+), linear power supply 1
10	DC 24 (-)	DC 24V (-), linear power supply 1 4 to 20 mA analog output
11	GND	Earth ground
12	DC 24 (+)	DC 24V (+), linear power supply 2

13	DC 24 (-)	DC 24V (-), linear power supply 2
14	NC2	Relay resting position (NC2)
15	NO2	Relay working position (NO2)
16	COM2	Relay common (COM2)
17	NC1	Relay resting position (NC1)
18	NO1	Relay working position (NO1)
19	COM1	Relay common (COM1)
20	---	No connection

## Meter Overview

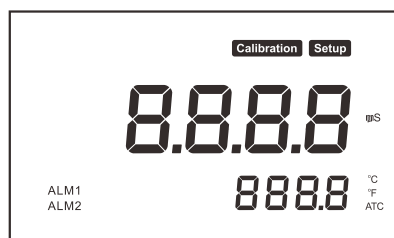

## Display

Icon	Description
Calibration	Indicates that the meter is in the calibration mode
Setup	Indicates that the meter is in the setup mode
ATC	Indicates that the automatic temperature compensation is enabled
ALM1	Indicates the measurement exceeded the high limit
ALM2	Indicates the measurement exceeded the low limit

## Keypad

Key	Function
⏻   🏠	<ul style="list-style-type: none"> <li>Switch the meter on or off</li> <li>Press and hold the key to enter the setup menu</li> <li>Exit the calibration, settings and return to the measurement mode</li> </ul>
▲   Cal	<ul style="list-style-type: none"> <li>Start calibration</li> <li>Increase value or scroll up the menu items</li> </ul>
▼   °C	<ul style="list-style-type: none"> <li>Set the temperature</li> <li>Decrease value or scroll down the menu items</li> </ul>
↻   Enter	<ul style="list-style-type: none"> <li>Toggle between the conductivity and TDS modes</li> <li>Confirm the calibration, setting or displayed option</li> </ul>

## Meter Setup

The BI-650 meter contains an integrated setup menu for customizing the displayed option to meet measurement requirement. The following table describes the functions of each menu item.

Menu Item	Option and Description
CELL	<b>Cell Constant</b> Set the cell constant to match connected conductivity electrode.
	1                      K = 0.1, 1, 10 (default 1)
CAL	<b>Calibration Points</b> Set the number of calibration points.
	2                      1 to 3 points (default 1 point)
COE	<b>Temperature Coefficient</b> Set the temperature coefficient for linear temperature compensation.
	2.1                    0.0 to 10.0%/°C (default 2.1)
TDS	<b>TDS Factor</b> Set the default TDS conversion factor.
	0.5                    0.1 to 1.0 (default 0.5)
UNIT	<b>Temperature Unit</b>
	°C                      Degrees Celsius (default)
	°F                      Degrees Fahrenheit
AL-L	<b>Low Alarm Limit</b> Setting range: 0.02 µS/cm to 20.00 mS/cm (default 0.02 µS/cm)
	<b>High Alarm Limit</b> Setting range: 20.00 mS/cm to 0.02 µS/cm (default 1000 µS/cm)
AL-H	<b>Hysteresis Value (Low)</b> Setting range: 1% to 99% (default 10%)
ALH1	<b>Hysteresis Value (High)</b> Setting range: 1% to 99% (default 1%)
ALH2	<b>Analog Output (Low)</b> Setting range: 0.02 µS/cm to 20.00 mS/cm (default 0.02 µS/cm)
AO-L	<b>Analog Output (High)</b> Setting range: 20.00 mS/cm to 0.02 µS/cm (default 20.00 mS/cm)
RS485	<b>Factory Reset</b> Reset the meter to factory default settings. Note, the meter must be recalibrated.
	YES                    Enable
	NO                     Disable (default)

AO-H

### Analog Output (High)

Setting range: 20.00 mS/cm to 0.02 µS/cm (default 20.00 mS/cm)

### Factory Reset

Reset the meter to factory default settings. Note, the meter must be recalibrated.

YES                    Enable

NO                     Disable (default)



- If the high or low alarm is enabled, the meter will be activated when the measurement exceeds specified limit. Note, this option can not enter the same values.
- If the hysteresis is enabled, the meter will prevent rapid contact switching when the measurement is fluctuating near the set point. For example, you have set the high alarm at 20 mS/cm and hysteresis value at 1%. When the measurement overshoots the 20.2 mS/cm, the meter will activate an external device. When the measurement drops to 19.8 mS/cm, the device will switch off.
- The default RS485 communication is 0.02 µS/cm to 20.00 mS/cm corresponds to the 4.00 to 20.00 mA.

### Setting a Default Option

- In the measurement mode, press and hold the key to enter the setup menu.
- Press the / key to select a menu item, press the **Enter** key to confirm.



- Press the / key to select an option or set a value, press the **Enter** key to save.



- To exit the setup menu without saving changes, press the key.

## Temperature Compensation

The BI-650 meter is supplied with an industrial conductivity electrode. When the wires of electrode are connected to the meter, the display will show ATC icon immediately. The meter is now switched to the automatic temperature compensation mode.



## Temperature Calibration

During the measurement, if the measured temperature reading differs from that of an accurate thermometer, the electrode needs to be calibrated.

1. Place the electrode into a solution with a known accurate temperature.
2. Press the **°C** key to enter the temperature setting.
3. Press the **▲ / ▼** key to modify the temperature value.
4. Press the **Enter** key to save.



## Selecting a Conductivity Electrode

The BI-650 meter is capable of using three types of electrodes. Before the calibration and measurement, ensure that you have selected a suitable electrode according to the anticipated sample conductivity. The following table lists the selectable electrode and its effective measurement ranges.

Electrode	Measurement Range	Cell Constant
IE-50LT	0.5 to 100 $\mu\text{S}/\text{cm}$	$K = 0.1$
IE-50MT	10 $\mu\text{S}/\text{cm}$ to 20 $\text{mS}/\text{cm}$	$K = 1$
IE-50HT	100 $\mu\text{S}/\text{cm}$ to 200 $\text{mS}/\text{cm}$	$K = 10$

## Conductivity Calibration

The BI-650 meter allows 1 to 3 points conductivity calibration. For better accuracy, we recommend to perform 3 points calibration or select a standard solution closest to the sample conductivity you are measuring. The meter will automatically detect the standard solution and prompt the user to perform the calibration. The following table shows the default standard solution for each measurement range.

Measurement Range	Default Standard Solution
20 to 200 $\mu\text{S}/\text{cm}$	84 $\mu\text{S}/\text{cm}$
200 to 2000 $\mu\text{S}/\text{cm}$	1413 $\mu\text{S}/\text{cm}$
2 to 20 $\text{mS}/\text{cm}$	12.88 $\text{mS}/\text{cm}$
20 to 200 $\text{mS}/\text{cm}$	111.8 $\text{mS}/\text{cm}$

### Single Point Calibration

Ensure that you have selected 1 point calibration in the setup menu.

- 1.1 Press the **Cal** key, the display shows **---/CAL I**, the meter waits for recognizing the standard solution.

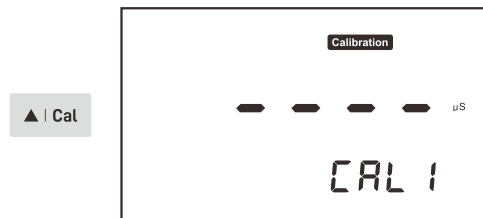

- 1.2 Rinse the conductivity electrode with distilled water, then rinse with a small amount of standard solution.
- 1.3 Place the electrode into the standard solution, the meter will automatically show the calibration standard (e.g., 1413  $\mu\text{S}/\text{cm}$ ).

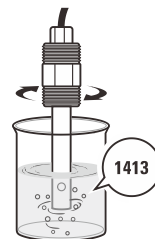

- 1.4 Press the **Enter** key, the default calibration value begins flashing.
- 1.5 Press the **▲ / ▼** key to set the calibration value, press the **Enter** key to confirm and move to next digit. When the setting is completed, ensure that displayed value matches your calibration standard.



1.6 Press the **Enter** key, the meter begins the calibration.

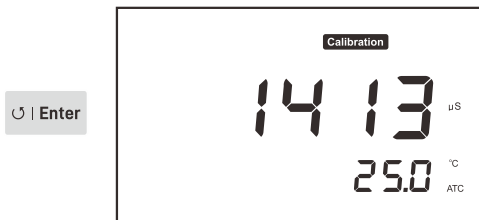

Wait for the reading to stabilize, the display will show *End*. Single point calibration is completed.

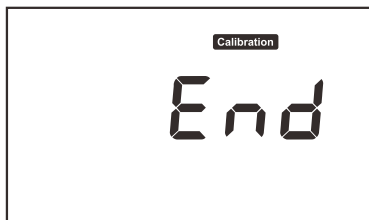

## Multipoint Calibration

Ensure that you have selected 2 or 3 points calibration in the setup menu.

- 2.1 When the first calibration point is completed, the display will show *---/CAL 2*. The meter prompts you to continue with second point calibration.
- 2.2 Repeat steps 1.2 through 1.6 above until the meter shows *End*. Calibration is completed.



- Performing the conductivity calibration will simultaneously calibrate the corresponding TDS value.
- To exit the calibration without saving changes, press the  $\text{⏏}$  key.

## Measurement

1. Press the  $\text{⏏}$  key to select the conductivity (*COND*) or TDS (*TDS*) mode.
2. Place the electrode into the sample. Wait for the measurement to stabilize.

## Communication

The BI-650 meter uses a standard Modbus-RTU protocol. All of the data are character type (2 bytes). The response data ranges between -32767 to 32767, hexadecimal.

### PC Command

Definition	Length of Byte	Data
ID address	1	0 × 02
Command	1	0 × 03
Start address	2	0 × 0001
Data number	2	0 × 0002
CRC16	2	0 × 95F8

### Meter Response

Definition	Length of Byte	Data
ID address	1	0 × 02
Command	1	0 × 03
Data Length	1	0 × 0002
Data	N	0 × 02 0 × BC
CRC16	2	0 × E4E8

- If the response is 01 indicating the command is error.
- If the response is 02 indicating the address is incorrect.
- If the response is 03 indicating the byte length is incorrect.

Command 03: Read the data from the measurement

Command 04: Read the data from the setting

- ID: 0 × 02 (Fixed)
- 03: Definition  
Address:  
0 × 0000 - Conductivity/TDS reading  
0 × 0001 - Decimal point  
0 × 0002 - Measurement unit  
0 × 0003 - Temperature (Reading × 0.1)
- 04: Definition  
Address:  
0 × 0000 - Read the low alarm limit  
0 × 0001 - Position of decimal point for the low alarm limit  
0 × 0002 - Measurement unit of the low alarm limit  
  
0 × 0003 - Read the high alarm limit  
0 × 0004 - Position of decimal point for the high alarm limit  
0 × 0005 - Measurement unit of the high alarm limit  
  
0 × 0006 - 4.00 mA correspond to conductivity value  
0 × 0007 - Position of decimal point for above value (4.00 mA)  
0 × 0008 - Measurement unit of above value (4.00 mA)

0 × 0009 - 20.00 mA correspond to conductivity value  
 0 × 000A- Position of decimal point for above value (20.00 mA)  
 0 × 000B- Measurement unit of above value (20.00 mA)

Decimal Point Response:

0 × 0000 (Reading × 1)  
 0 × 0001 (Reading × 0.1)  
 0 × 0002 (Reading × 0.01)  
 0 × 0003 (Reading × 0.001)

Measurement Unit Response:

0 × 0006: mS/cm  
 0 × 0007: μS/cm  
 0 × 0008: ppt  
 0 × 0009: ppm

For Example (Hexadecimal):

PC send: 02 03 00 00 00 02 C4 38  
 (Read the conductivity)

Response: 02 03 02 02 BC FC 95  
 (700)

PC send: 02 03 00 01 00 02 95 F8  
 (Read the decimal point)

Response: 02 03 02 00 01 3D 84  
 (Reading × 0.1)

PC send: 02 03 00 02 00 02 65 F8  
 (Read the measurement unit)

Response: 02 03 02 00 07 DB 86  
 (μS/cm)

The result will show 70.0 μS/cm (700 × 0.1 μS/cm)

## Electrode Maintenance

In order to maintain an accurate measurement, the electrode needs cleaning and regular maintenance.

- Remove the conductivity electrode from service and rinse the platinum sensor on the bottom of the electrode.
- Do not touch the platinum black coating on the sensor surface and always keep it clean.
- If there is a build-up of solids inside the sensor, remove carefully, then recalibrate the electrode.
- If you do not use the electrode for long periods, wipe clean with a lint-free tissue and store the electrode in a dry and cool area.
- If your electrode is model IE-50HT, store the electrode with tap water. This sensor needs to be kept wet always.

Platinum  
black coating

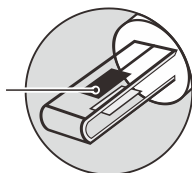

## Appendix

### Troubleshooting

Fault	Cause and Corrective Action
Screen shows - - - -	Electrode dried out. Soak the conductivity electrode in tap water for about 10 minutes.
Drifting erratic readings	Measurement exceeded the maximum range. Check the electrode and sample.
Screen shows E r r	Check whether electrode is contaminated, clogged or broken.  Setting value does not match calibration solution. Reset the calibration value or check the calibration solution.
	Electrode is broken. Replace the conductivity electrode.

### Preparation of Conductivity Standard Solutions

1. Place the analytical grade potassium chloride (KCl) in a beaker and dry in an oven for about 3 hours at 105°C (221°F), then cool to room temperature.
2. Add the reagent to a 1 liter volumetric flask according to the instructions in table below.

Conductivity Standard	Reagent	Weight
84 μS/cm	KCl	42.35 mg
1413 μS/cm	KCl	745.5 mg
12.88 mS/cm	KCl	7.45 g
111.8 mS/cm	KCl	74.5 g

3. Fill the distilled water to the mark, mix the solution until the reagent is completely dissolved.

### Calculating the Temperature Coefficient

1. Do not connect the temperature probe to the meter.
2. Press and hold the °C key to enter the temperature setting.
3. Press the ▲ / ▼ key to set the temperature to 25°C and press the **Enter** key to confirm.
4. Place the conductivity electrode into the sample solution, record the temperature value  $T_A$  and conductivity value  $C_{TA}$ .
5. Condition the sample solution and electrode to a temperature  $T_B$  that is about 5 to 10°C different from  $T_A$ . Record the conductivity value  $C_{TB}$ .
6. Calculate the temperature coefficient using the formula below.

$$T_C = [C_{TB} - C_{TA}] / [C_{TA}(T_B - 25) - C_{TB}(T_A - 25)]$$

Where:

$T_C$  = Temperature coefficient

$C_{TA}$  = Conductivity at temperature A

$C_{TB}$  = Conductivity at temperature B

$T_A$  = Temperature A

$T_B$  = Temperature B

### Calculating the TDS Conversion Factor

To determine the TDS factor of sample solution use the formula below.

$$\text{Factor} = \text{Actual TDS} / \text{Actual Conductivity @25}^\circ\text{C}$$

Where:

Actual TDS = value from the high purity water and precisely weighed NaCl or KCl reagent

Actual Conductivity = the meter measured conductivity value

For example:

Dissolve 64 grams of the potassium chloride (KCl) reagent in 1 liter distilled water. If measured conductivity is 100 mS/cm, then TDS factor is 0.64.

### Optional Accessories

Order Code	Description
IE-50LT	For measuring low conductivity liquids / pure water
IE-50MT	For general purpose applications
IE-50HT	For measuring high conductivity liquids / wastewater
ECCS-84	Conductivity standard solution 84 $\mu\text{S}/\text{cm}$ , 480 ml
ECCS-1413	Conductivity standard solution 1413 $\mu\text{S}/\text{cm}$ , 480 ml
ECCS-1288	Conductivity standard solution 12.88 mS/cm, 480 ml
ECCS-1118	Conductivity standard solution 111.8 mS/cm, 480 ml

### Meter Specifications

Model	BI-650
<b>Conductivity</b>	
Range	0.01 $\mu\text{S}/\text{cm}$ to 200.0 mS/cm
Resolution	0.001, 0.01, 0.1, 1
Accuracy	$\pm 1\%$ F.S.
Calibration Points	1 to 3 points
Calibration Solutions	84 $\mu\text{S}/\text{cm}$ , 1413 $\mu\text{S}/\text{cm}$ , 12.88 mS/cm, 111.8 mS/cm
Temperature Compensation	0 to 100°C (32 to 212°F), automatic
Temperature Coefficient	0.0 to 10.0%/°C

Reference Temperature	25°C
Cell Constant	K = 0.1, 1, 10
<b>TDS</b>	
Range	0.00 to 10.00 ppt (max. 200 ppt)
Resolution	0.01, 0.1, 1
Accuracy	$\pm 1\%$ F.S.
TDS Factor	0.1 to 1.0 (default 0.5)
<b>Temperature</b>	
Range	0 to 100°C (32 to 212°F)
Resolution	0.1°C (0.1°F)
Accuracy	$\pm 1^\circ\text{C}$ ( $\pm 1.8^\circ\text{F}$ )
Calibration Point	1 point
<b>Communication</b>	
Signal Output	4 to 20 mA
Low or High Alarm	0.02 $\mu\text{S}/\text{cm}$ to 20.0 mS/cm
Load	500 $\Omega$
Communication Interface	RS485
<b>Other Specifications</b>	
Operating Temperature	5 to 50°C (41 to 122°F)
Storage Temperature	0 to 60°C (32 to 140°F)
Relative Humidity	< 80% (non-condensing)
Display	LCD, 70 x 45 mm (2.9 x 1.7 in.)
Power Requirements	DC 24V
Dimensions	96 (L) x 96 (W) x 75 (H) mm, (3.7 x 3.7 x 2.9 in.)
Weight	350 g (12.3 oz.)

## Disposal

This product is required to comply with the European Union's Waste Electrical and Electronic Equipment (WEEE) Directive 2002/96/EC and may not be disposed of in domestic waste. Please dispose of product in accordance with local regulations at the collecting point specified for electrical and electronic equipment.



## Warranty

The warranty period for meter is one year from the date of shipment. Above warranty does not cover the electrode and standard solution.

Out of warranty products will be repaired on a charged basis.

The warranty on your meter shall not apply to defects resulting from:

- Improper or inadequate maintenance by customer
- Unauthorized modification or misuse
- Operation outside of the environment specifications of the products

For more information, please contact the supplier.



Office: 4715 Castlewood St., Sugar land, TX 77479, USA

Tel: (+1) 346-762-7358

E-mail: banteinstruments@yahoo.com

Factory: 2185 Laifang Rd., Shanghai 201615, China

Tel: (+86) 21-6404-1598

E-mail: banteinstrument@hotmail.com

 [www.bante-china.com](http://www.bante-china.com)



The information in this document is subject to change without notice.  
Copyright © Bante Instruments Inc, 2022. All rights reserved.